

JetFlex® TD 65-2 G Tube Diffuser





Dimensions

Material	Tube diameter	ID-Sleeve	Wall thickness
EPDM	63 mm	~ 65 mm	1.9 ± 0.15 mm
Silicone	63 mm	~ 65 mm	1.5 ± 0.15 mm
PUR	63 mm	~ 65 mm	0.75 ± 0.025 mm



Installation drawing

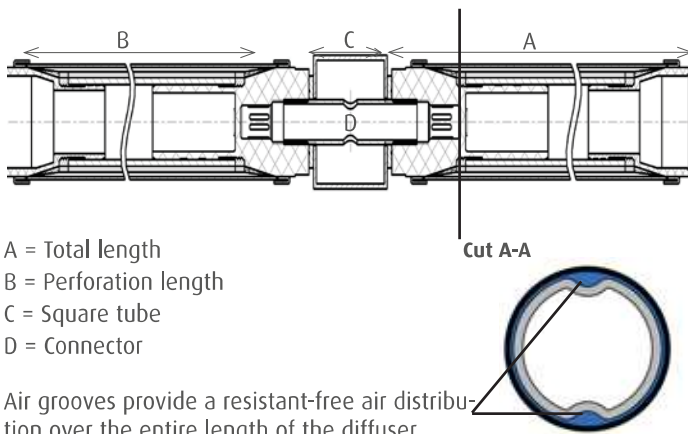

A = Total length
 B = Perforation length
 C = Square tube
 D = Connector

Air grooves provide a resistant-free air distribution over the entire length of the diffuser.

SSOTE and headloss for EPDM 1000 mm

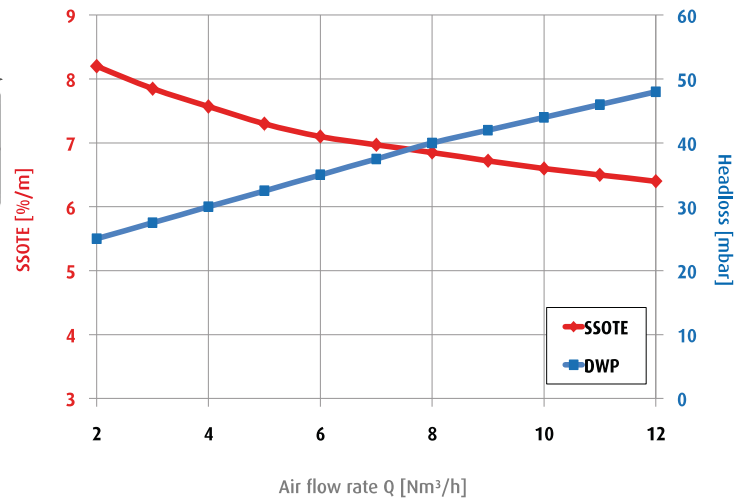

Perforation length [B]	Total length [A]	Perforated area		Air flow rate at standard operating conditions		Max. overload / maintenance air flow rate		Operating mode
		EPDM	SI+PU	EPDM + SI	PU	EPDM + SI	PU	
1000 mm	1080 mm	0.18 m²	0.16 m²	2 - 12 Nm³/h	3 - 8 Nm³/h	20 Nm³/h	16 Nm³/h	continuous / intermittent
750 mm	830 mm	0.135 m²	0.12 m²	1.5 - 9 Nm³/h	2 - 6 Nm³/h	15 Nm³/h	12 Nm³/h	continuous / intermittent
500 mm	580 mm	0.09 m²	0.08 m²	1 - 6 Nm³/h	1 - 4 Nm³/h	10 Nm³/h	8 Nm³/h	continuous / intermittent

Dimensions for connection to square pipes

Connector [D]	Connector length square tube 80 x 80 mm [C]	Connector length square tube 100 x 100 mm [C]	Drill hole for connector
Pipe thread ISO 228 - G 1A	145 mm	165 mm	35 +1/-0 mm
Pipe thread ISO 228 - G 3/4A	145 mm	165 mm	28 +1/-0 mm

Please see our operation manuals for more details.



Membrane materials

Material	Techn. standard	EPDM	PUR	Techn. standard	Silicone
Colour		black	transparent		translucent
Plasticiser (%)		35	0		0
Density (g/cm ³)	DIN EN ISO 1183-1	1.11	1.13	DIN EN ISO 1183-1	1.16
Tensile strength (N/mm ²)	DIN 53504	>7	>45	DIN 53504	>9
Elongation at break (%)	DIN 53504	>400	>450	DIN 53504	>900
Tear strength (N/mm)	DIN EN ISO 34-1	>7,5	>35	ASTM D 624 B	>38
Hardness (Shore A)	DIN ISO 7619-1	40 ± 5	80 ± 5	DIN 53505	60 ± 5
Operating air temperature (°C)		5 - 80	5 - 60		5 - 100
Operating water temperature (°C)		5 - 40	5 - 40		5 - 40

Other materials

Support tube	SS clamp
PP / PP 20% GF	1.4301

Accessories



Stainless steel connector (square header)



Adapter



Blind plug



L-bracket and end plug



Plastic connector / Sealing saddle (round header)



Clamp adapter (round header)

Please see our accessories catalogue for more details.